

BEFORE YOU START**General Site Working**

BS 8000 Workmanship on building sites, Parts 13 through to 16 with respect to above ground drainage and sanitaryware appliances are relevant in general terms.

Handling and Storage

Gutters, downpipes and fittings, particularly with polyester powder coat finish should be handled with care and preferably stored under cover on racks to prevent scratching. Whilst not known to pose any health hazard, it is recommended that protective gloves be worn when handling mill finish aluminium.

All lengths are supplied in a protective polythene wrapping with components similarly wrapped and stored in cardboard boxes. If painted product is to be stored outside, cover with tarpaulin to protect against rainfall and direct sunlight as if water gets trapped inside the protective covering and is exposed to warm sunlight then it may leave permanent watermarks on the paint finish. Mill finish items should be stored under cover to avoid uneven oxidization prior to being fitted.

Cutting and Drilling

Gutter sections may be cut and drilled on site using standard metalworking tools, however the use of angle grinders is not recommended. Where gutters or fittings are powder coated, then cut edges should be de-burred and then repainted with touch-up paint (available from ARP).

Gutter Position

Gutters may be laid level or to a fall of 1:600. Care must be taken to ensure the gutters are not laid too low so rainfall overshoots the gutter, or too high so that damage could be caused by sliding snow. Although at the discretion of the installer and dependant upon local climatic conditions and roof slope/finish, setting out with the front edge of the fascia bracket in line with the pitch of the roof (use straight edge) is a recommended method.

Gutter Position

The current recommendations from the Metal Gutter Manufacturers Association (MGMA) is to position gutters as Fig 1.

Fig 1 is more resistant to sliding snow than Fig 2.

There are certain conditions where a Fig 1 installation might allow water to over shoot the gutter or high wind conditions may allow water to blow back behind the gutter.

Fig 1 is the preferred option for the majority of the UK, but the decision should be made based on site conditions. We can provide more detailed advice if required.

Materials Checklist

- Spirit level/straight edge
- Suitable screwdriver/attachment
- Sealant caulking gun
- Pencil or chalk
- String or laser line
- Hacksaw/electric jigsaw/chopsaw
- Tape measure
- Small wrench

Jointing

Any use of sealant must not be carried out in wet weather or in temperatures below 5°C or above 50°C. All Joint surfaces must be perfectly clean and dry. Only a low modulus sealant must be used to prevent early failure. Ensure that the gutter joint sockets/spigots are correctly aligned with each other to ensure free thermal movement (3-4mm) within the gutter joint.

Fixing

It is important that all fixings are suitable for both the substrate and the load. They must therefore be of the appropriate size and of a compatible material to ensure no electrolytic corrosion occurs. ARP recommends that stainless steel (preferably austenitic) screws must be used to fix gutters, whether direct, fascia or rafter bracket fixed.

The below table shows the system and bracket options available.

	Fascia Brackets	Direct Fix	Rafter Brackets	Rise & Fall Brackets
Beaded Half Round	Y	N	Y	Y
Deepflow Half Round	Y	N	Y	Y
Vintage Ogee Snap-fit	Y	Y	Y	Y
Modern Ogee	N	Y	N	N

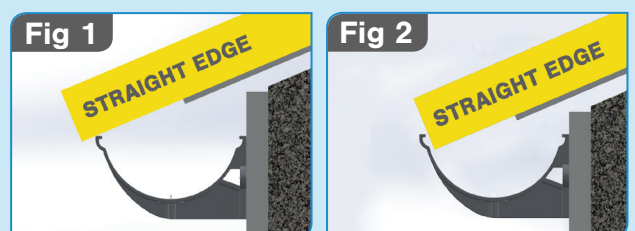

Installation Guide

BEADED HALF ROUND SNAP-FIT GUTTERING



GUTTER FIXING

We advise that you ensure the fixing background (e.g fascia board) is securely fixed, level and able to support the weight of the gutter at full capacity and that the roof overhang is correct – see gutter position.

Buildings without fascias may need a different type of bracketry. ARP offer a range of brackets to suit most applications. ARP offer side and top fix rafter arms as well as rise and fall brackets. The latter do not meet current BS/EN load requirements so advice should be sort on the parameter of their use.

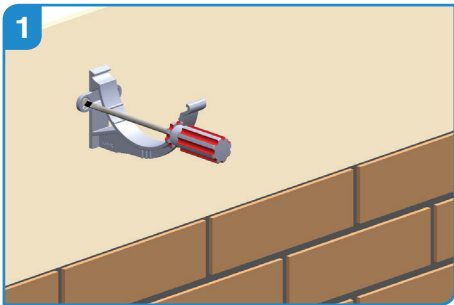

1 Start by deciding whether to fit the gutter level or with a fall to 1:600. Fit a bracket at each end of a run. Position brackets correctly for an angle or stepend.

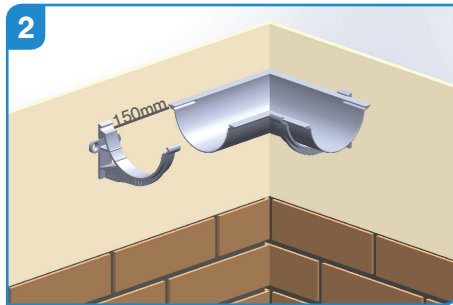

2 Image 2 shows the bracket positioning for the angle and bracket to take the gutter length.

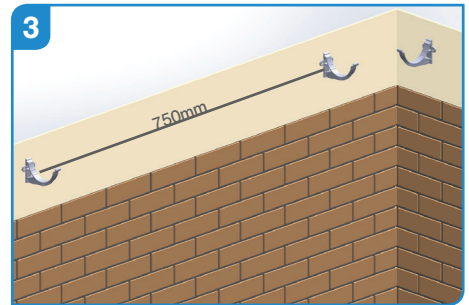

3 We recommend fixing brackets every 750mm and using an additional bracket for each outlet or angle. Ideally using a string line or laser level between the two brackets, set out intermediate brackets at maximum centres of 750mm.

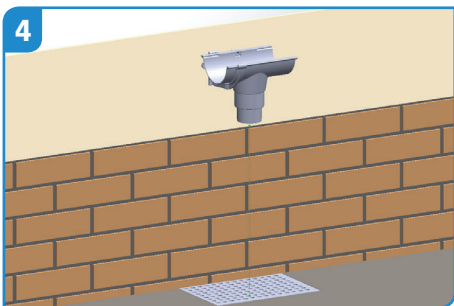

4 With the use of a plumb or laser line, position outlets over gullies and support with at least one bracket. Also include a bracket per angle (internal or external).

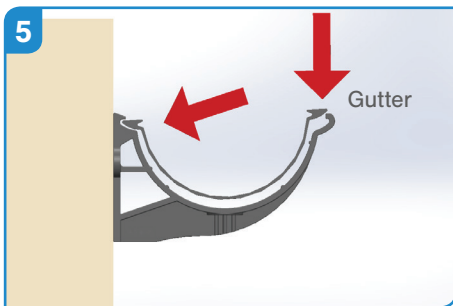

5 When fitting outlets and angles tuck the rear face of the gutter underneath the roof finish. Locate the gutter into the fascia bracket and then clip the front edge down into position.

After fitting outlets and angles, proceed with fitting the gutter lengths using the same method.

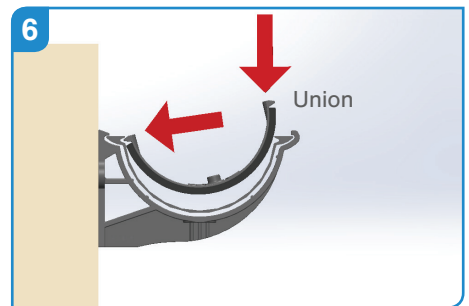

6 Ensure that all fixing surfaces are clean and dry. Placing the union into the groove in the rear face of the gutter and clip down into place on the front edge.

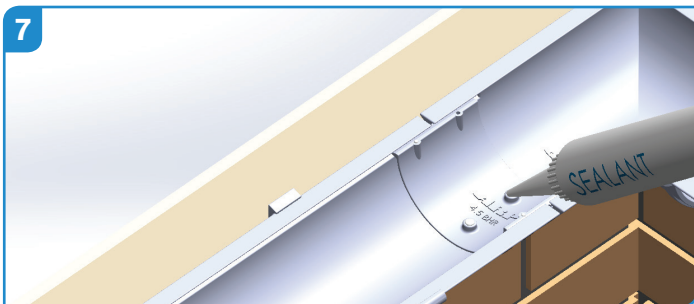

7 Trim 4-5 mm off top of nozzle so it fits snugly into the large holes in the base of the union, inject the special* low modulus sealant supplied into one of the large holes in the bottom of the union until the sealant appears at both of the smaller holes at the rim of the union. Repeat the action on the other large hole. (*Sealant only available from ARP).

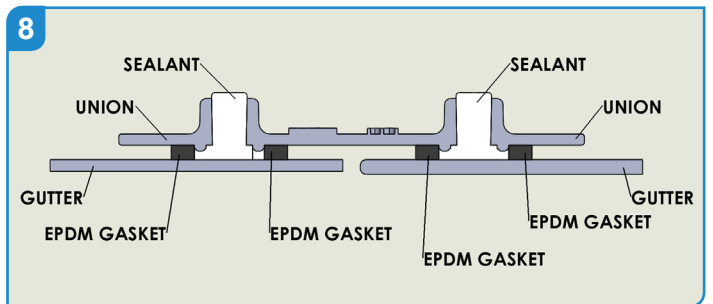

8 Ensure you apply the sealant gently to ensure the void is fully filled.

Clean off any excess sealant and then use the same process for every joint until the work is completed.



Any cut lengths should be de-burred and touched up with touch-up paint supplied prior to installation. For more information or further assistance, please contact us.